

## Assembly and Installation Instructions

### Plate Heat Exchanger brazed material series

### D-PWT 30-50-75

If you do not pay proper attention to these installation instructions the manufacturer cannot accept liability for any resulting damage to the device itself, the environment, property, or personal injury.

#### Your safety is our concern!

These counter flow heat exchangers are made out of stainless steel AISI and consist of stacked copper brazed plates. In order to build separated flow space one plate is always turned 180° in relation to the next one.

### 1. Safety Warnings:

This device has not been designed for use by individuals (including children) with physical, mental or sensory disabilities or who lack the necessary experience and/or knowledge unless under the supervision of someone entrusted with their safety or instructed by that person in how the device should be used.

### 2. Purpose:

- 2.1 These Plate Heat Exchangers are designed to heat up bathing water using warm water.
- 2.2 Thanks to the large exchange surface they are excellently suitable for using low temperature heating systems, for example, solar heating systems, geothermal plants, heat pumps and similar alternative and innovative heating systems.
- 2.3 The heating of the bathing water happens through a bypass system. At full flow in the bathing water cycle the pressure built up would be too high for the pipe system. The pool-side flow is regulated by a ball valve, by which the capacity of the plate heat exchanger is affected. To obtain optimal capacity please note point 8 "technical data".

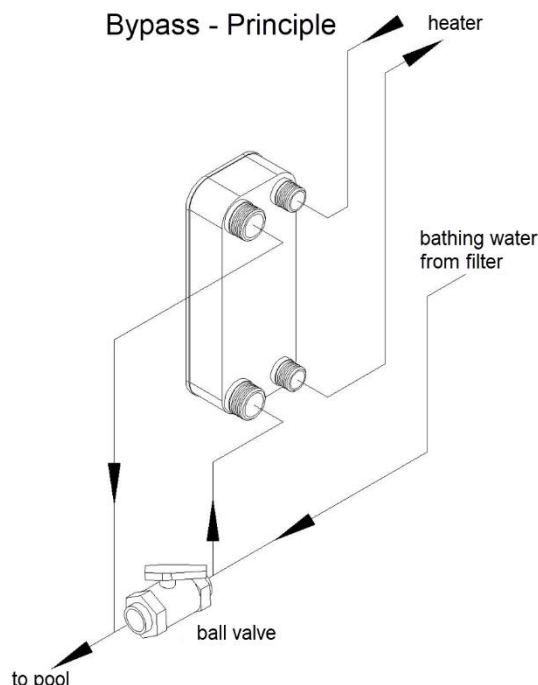

### 3. Hazards:

- 3.1 The stacking of multiple plates can cause sharp edges. In order to prevent cut injuries always use appropriate safety gloves during installation.
- 3.2 To prevent loss of energy and danger, like burn injuries and pipe damage caused by overheating, the filter pump must stop the heating pump and a non-return valve must be installed on the primary heating side of the heat exchanger. It should not be possible to switch on the heating pump when the filter pump is switched off! It is recommended to install a switch-off delay for the filter pump. The heating pump should be disconnected from the mains approximately 10 minutes before the filter pump.
- 3.3 To prevent damage to the heat exchanger and the surroundings, the heat exchanger needs to be monitored regularly during the bathing season (at least once a week) for external signs of damage and leaks.

## 4. Installation:

- 4.1 The heat exchanger must always be installed after the filter.
- 4.2 Pipe systems in new and rehabilitated facilities need to be rinsed before mounting the plate heat exchanger! Soiling can cause blockage of the plate heat exchanger.
- 4.3 Be careful! Vibrations in the pipes could harm the connectors of the plate heat exchanger.
- 4.4 During assembly the directions given in the diagram need to be followed exactly (see 4.9 and 4.10). This way damage and loss in performance can be avoided.
- 4.5 To prevent damage caused by corrosion, be careful not to introduce metals into the heat exchanger containing iron (contact corrosion). If the plate heat exchanger is assembled on the ground, make sure the area is absolutely dry to prevent corrosion on the surface of the plate heat exchanger.
- 4.6 It is essential to make sure that the heat exchanger is always full of water when the bathing facility is closed for the winter (above and below the water level). If there is a risk of frost in a facility, the heat exchanger must be completely emptied. Under frost conditions, vertical positioning of the heat exchanger is recommended. The heating circuit can also be protected with antifreeze, like glycol.
- 4.7 Check all connections for possible leaks after the initial start-up.
- 4.8 If the heat exchanger fails to perform properly after the initial start-up, all air must be removed from the primary side (A/B). The water inlet and outlet (see diagram A-B/C-D) should be checked to ensure that they have been properly installed.
- 4.9 Installation layout above water level

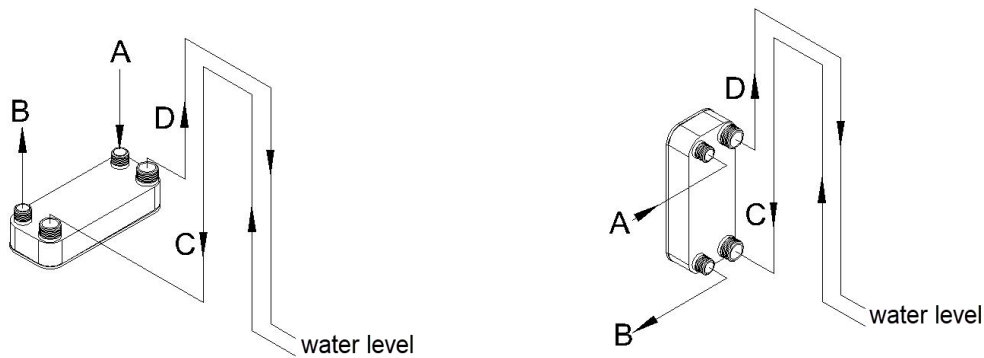

### 4.10 Installation layout below water level

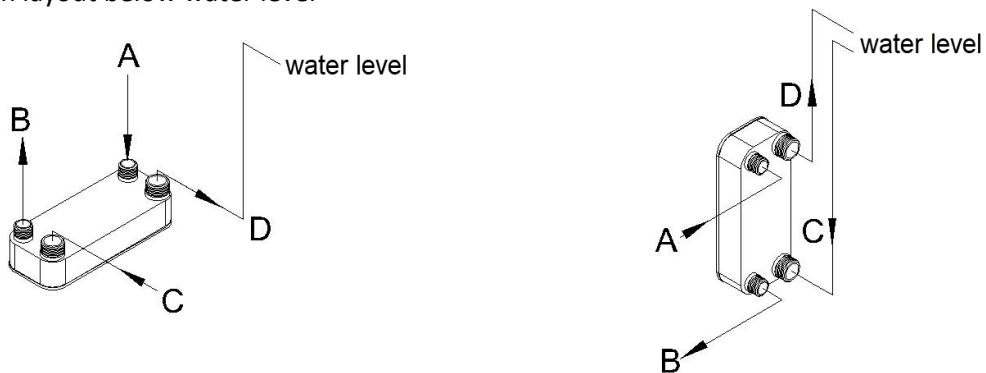

## 5. Incorrect assembly:

The following order of assembly is incorrect because air-and gas bubbles cannot escape, which can lead to corrosion in the plate heat exchanger:

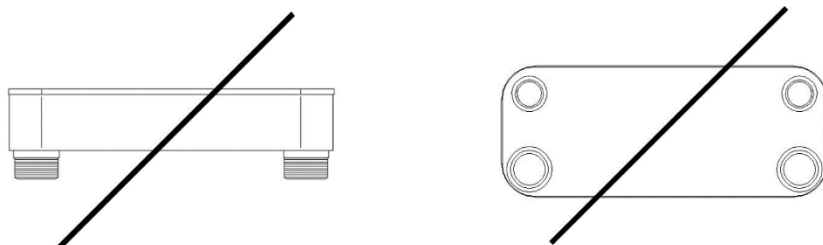



## 6. Important information regarding water quality:

Make sure that water quality is achieved within the following parameters:

**Stainless steel AISI:** Chloride content: max. 500 mg/l  
Free chlorine: max. 1 mg/l  
PH: max. 6,8 – 7,8

If these limits are not taken into account, the heat exchanger may be damaged.

**Please note:** Sterilizing units should be installed after the heat exchanger and in such way that no chemicals or gases can enter the heat exchanger when it is not in use.

## 7. Important general note:

It is essential that the heat exchanger is installed in an area with adequate floor drainage. If heat exchangers, filters and similar devices are damaged, water may escape uncontrollably. Cellars and similar areas may quickly become flooded and suffer material damage!

**Please keep these assembly and installation instructions on file for further reference. Thank you!**

Update: **05.07.2022**

**Max Daprà sas - Daprà Andreas & Co, Via Graf 2, I-39050 Fiè allo Sciliar**  
**technical changes reserved**

## 8. Technical Data:

Technical Information	D-PWT 30	D-PWT 50	D-PWT 75
heat capacity	30 kW	50 kW	75 kW
primary in/out	55/38°C	55/34°C	55/32°C
heat capacity	23 kW	36 kW	55 kW
primary in/out	45/32°C	45/30°C	45/28°C
heat capacity	16 kW	22 kW	35 kW
primary in/out	35/26°C	35/26°C	35/24°C
primary flow	1,5 m <sup>3</sup> /h	2,1 m <sup>3</sup> /h	2,8 m <sup>3</sup> /h
secondary flow	1,8 m <sup>3</sup> /h	2,2 m <sup>3</sup> /h	3 m <sup>3</sup> /h
pressure loss primary	0,29 bar	0,22 bar	0,13 bar
pressure loss secondary	0,30 bar	0,25 bar	0,16 bar
basis of calculation secondary	20°C	20°C	20°C
basis of calculation pipe pressure	0,62 bar	0,62 bar	0,62 bar
installation pool	bypass	bypass	bypass
number of plates	14	20	38
area	0,31 m <sup>2</sup>	0,54 m <sup>2</sup>	1,08 m <sup>2</sup>
material of plates	AISI 316	AISI 316	AISI 316
max. temperature	195°C	195°C	195°C
max. pressure	30 bar	30 bar	30 bar
empty weight	3,3 kg	4,5 kg	7 kg
water content	0,77 l	1,3 l	2,47 l
brazed with	copper	copper	copper