

Assembly and Installation Instructions

Plate Heat Exchanger of the Series X-PWT / G-PWT / 13M-PWT / LT-PWT

If you do not pay proper attention to these installation instructions the manufacturer cannot accept liability for any resulting damage to the device itself, the environment, property, or personal injury.

Your safety is our concern!

These counter flow heat exchangers consist of stacked, bolted plates made from stainless steel AISI or titanium, separated with gaskets, in which one plate is turned 180° with the other in order to build flow space that is separated from each other.

1. Safety Warnings:

This device has not been designed for use by individuals (including children) with physical, mental, or sensory disabilities or who lack the necessary experience and/or knowledge unless under the supervision of someone entrusted with their safety or instructed by that person in how the device should be used.

2. Purpose:

- 2.1 These Plate Heat Exchangers are designed to heat up bathing water using warm water.
- 2.2 Thanks to the large exchange surface they are excellently suitable for using low temperature heating systems, for example, solar heating systems, geothermal plants, heat pumps and similar alternative and innovative heating systems.
- 2.3 The heating of the bathing water happens through a bypass system. At full flow in the bathing water cycle the pressure built up would be too high for the pipe system. The pool-side flow is regulated by a ball valve, by which the capacity of the plate heat exchanger is affected. To obtain optimal capacity please note point 11 "technical data".

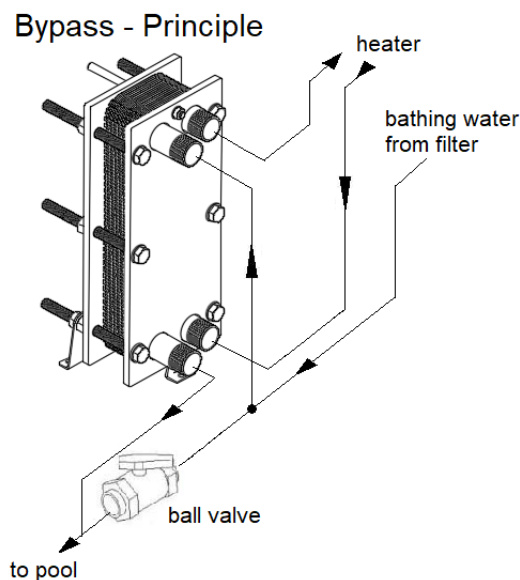

3. Hazards:

- 3.1 The stacking of multiple plates can cause sharp edges. In order to prevent cut injuries always use appropriate safety gloves during installation. During maintenance work the temperature on the heat exchanger must be under 35°C. The pipes cannot be under pressure.
- 3.2 To exclude loss of energy and danger like burn injuries and pipe damage caused by overheating, the filter pump must stop the heating pump and a non-return valve must be installed on the primary heating side of the heat exchanger. It should not be possible to switch on the heat pump when the filter pump is switched off! It is recommended to install a switch-off delay for the filter pump. The heating pump should be disconnected from the mains approximately 10 minutes before the filter pump.
- 3.3 To prevent damage to the heat exchanger and the surroundings, the heat exchanger needs to be monitored regularly during the bathing season (at least once a week) for external signs of damage and for leaks.

4. Installation:

- 4.1 The plate heat exchanger must always be installed after the filter.
- 4.2 Pipe systems in new and rehabilitated facilities need to be rinsed before mounting the plate heat exchanger! Soiling can cause blockage of the plate heat exchanger.
- 4.3 Be careful! Vibrations in the pipes could harm the connectors of the plate heat exchanger.
- 4.4 During assembly the directions given in the diagram (see 4.9 and 4.10) need to be followed exactly. This way damage and loss in performance can be avoided. Ensure that there are no loops in the pipes, which may hinder the flow of water!
- 4.5 To prevent damage caused by corrosion, be careful not to introduce metals into the heat exchanger containing iron (contact corrosion). If the plate heat exchanger is assembled on the ground, make sure the area is absolutely dry to prevent corrosion on the surface of the plate heat exchanger.
- 4.6 Check all connections for possible leaks after the initial start-up.
- 4.7 If the heat exchanger fails to perform properly after the initial start-up, all air must be removed from the primary side (A/B). The water inlet and outlet (see diagram A-B/C-D) should be checked to ensure that they have been properly installed.
- 4.8 Install a backflow preventer on the primary input (A) as overheat protection.
- 4.9 Installation layout above water level

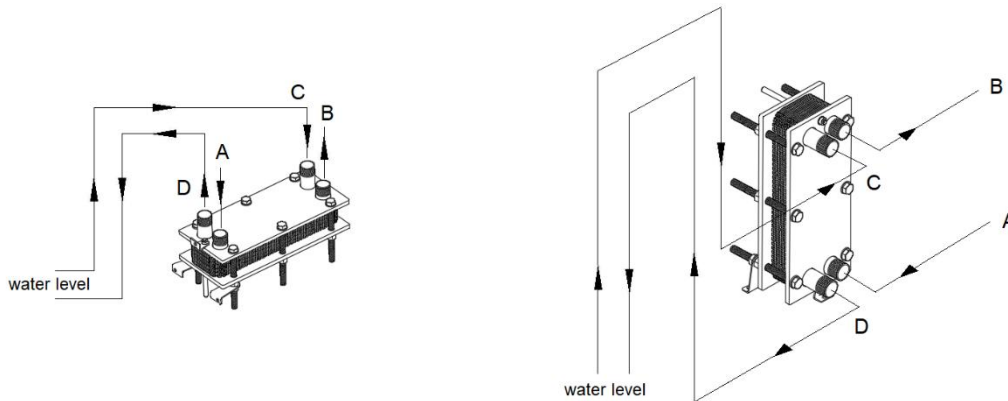

4.10 Installation layout below water level

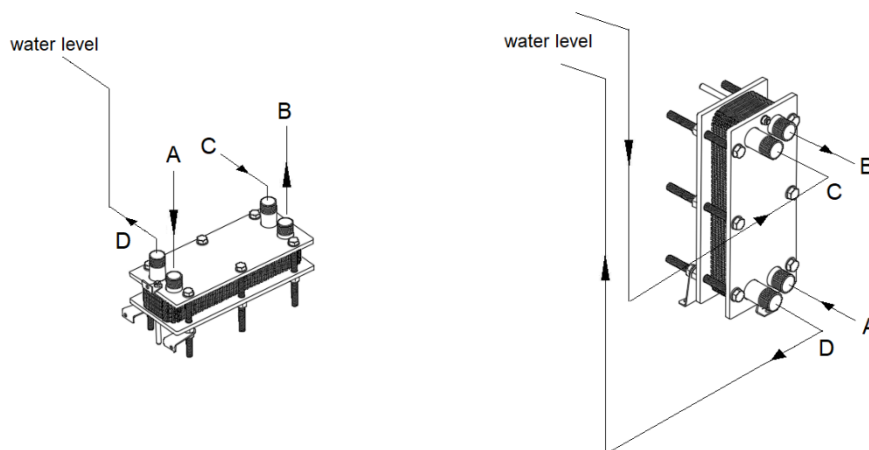

5. Winterize and Storage:

- 5.1 It is essential to make sure that the heat exchanger is always full of water when the bathing facility is closed over the winter (above and below the water level). If there is a risk of frost in a facility, the heat exchanger must be completely emptied. Under frost conditions, vertical positioning of the heat exchanger is recommended. The heating circuit can also be protected with antifreeze, like glycol.
- 5.2 If a plate heat exchanger will not be used for an extended period of time, it should be completely emptied and cleaned. In order to put minimal pressure on the plates, the nuts should be loosened. The heat exchanger should be wrapped in a non-transparent cloth to avoid daylight damage to the valves. Please make sure the nuts are evenly tightened and "frame distance inside" (see 12. Technical data – "J") is reached before reassuming operation.

6. Incorrect assembly:

The following order of assembly is incorrect because air-and gas bubbles cannot escape, which can lead to corrosion in the plate heat exchanger:

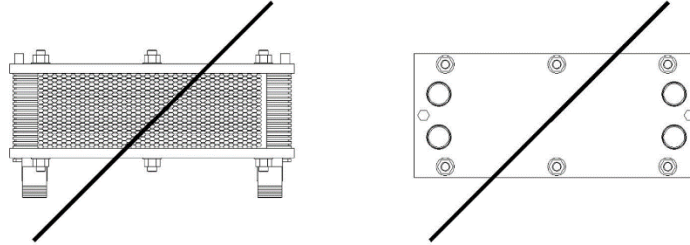

7. Important information regarding water quality:

Make sure that water quality is achieved within the following parameters:

Stainless steel AISI:

Chloride content: max. 500 mg/l
Free chlorine: max. 1 mg/l
PH: max. 6,8 – 7,8

Titanium:

Chloride content: max. 3000 mg/l
Free chlorine: unlimited
PH: max. 6,8 – 7,8
Salt: max. 3%

If these limits are not taken into account, the heat exchanger may be damaged.

Please note: Sterilizing units should be installed after the heat exchanger and in such way that no chemicals or gases can enter the heat exchanger when it is not in use.

8. Extension of the plate number:

- 8.1 Please note point 3 „Hazards “
- 8.2 Please be careful to loosen the nuts evenly when opening the plate heat exchanger. Also, during re-assembly of the exchanger, a uniform contraction is necessary.
- 8.3 **Plates should only be added in pairs**, otherwise the ratio between primary and secondary sides will not match.
- 8.4 The first and last plates are special plates and need to be remounted in first and last position.
- 8.5 Before the plates are mounted make sure that the plates are clean and that the gaskets are free of oil stains and other soiling.
- 8.6 The plates need to be inserted in the plate guide. Be careful to make sure each plate is turned 180° in relation to the previous one.
- 8.7 The frame distance needs to be recalculated. Multiply the new amount of plates by 2,9 mm in order to get the new „Frame Distance Inside “e.g. 27 plates x 2,9 mm = 78,3 mm.
- 8.8 Important: while tightening the screws, please keep in mind the calculated amount of the „Frame Distance Inside “, otherwise the operating pressure of 10 bar won't be reached.

9. Cleaning:

- 9.1 Individual plates of a disassembled heat exchanger can be cleaned manually with a soft brush and an appropriate cleaner. Never use steel brushes, sandpaper or other tools which could damage the plates or the gaskets. The cleaner used, should not damage the plates or the gaskets!
- 9.2 It is also possible to flush the assembled plate heat exchanger with a chemical cleaner. For grease and other organic deposits, use a caustic soda (concentration max. 1,5% at maximal temperature of 85°C). With calcification nitric acid can be used (concentration max. 1,5% at a maximal temperature of 85°C). Nitric acid also has a positive impact on the passivation of stainless steel. In both cases, after cleaning, the equipment must be carefully flushed with cold water! In order to not expose the equipment to the acids for too long, we suggest dismantling the plate heat exchanger when heavily soiled, and clean it as explained in 9.1.

10. Important general note:

It is essential that the heat exchanger is installed in an area with adequate floor drainage. If heat exchangers, filters and similar devices are damaged, water may escape uncontrollably. Cellars and similar areas may quickly become flooded and suffer material damage!

Please keep these assembly and installation instructions on file for further reference. Thank you!

Update: **24.03.2026**

Max Daprà sas - Daprà Andreas & Co, Via Graf 2, I-39050 Fiè allo Sciliar
technical changes reserved